

M DRIVE 34

MOTOR+DRIVER

SPEED CONTROL



FEATURES

- Integrated Variable Speed Controller, Microstepping Driver and NEMA 34 High Torque 1.8° Stepping Motor
- +24 to +75 VDC Input Voltage
- Digital Oscillator for Accurate Speed Control
- Optically Isolated Logic Inputs will Accept +5 to +24 VDC Signals, Sourcing or Sinking
- Step Clock and Direction Outputs
- Low Cost
- Extremely Compact
- Available Configurations:
 - Single Shaft*
 - Long Life Linear Actuator
 - Optical Encoder*
 - Control Knob for Manual Positioning*
 - Integrated Planetary Gearbox*
- Three Stack Sizes Available*
- Electronically Configurable (Eliminates Potentiometers):
 - Motor Run/Hold Current
 - Acceleration/Deceleration
 - Initial and Max Velocity
 - Speed Control Input Source
 - Microstep Resolution to 256 Microsteps/Full Step
 - Motor Direction vs. Direction Input
- 2 Modes of Operation: Bidirectional or Unidirectional
- Selectable Speed Control from One of Two 0 to +5 VDC Inputs (One Configurable as 0-20 or 4-20mA) or 15 to 25kHz PWM Input, all with Programmable Center Point
- Single Supply
- Interface Uses 12.0" (30.5cm) Flying Leads
- Graphical User Interface (GUI) for Quick and Easy Parameter Setup

* Rotary Motor Only

DESCRIPTION

The MDrive34 Speed Control offers the system designer low cost, intelligent velocity control integrated with a NEMA 34 high torque stepping motor and a +24 to +75 volt microstepping driver.

This product features a digital oscillator for accurate velocity control with an output frequency of up to 100kHz. Output frequency will vary with the signal applied to the speed control inputs.

Speed may be adjusted by 15-25kHz PWM or one of two 0-5volt input signals, one configurable as 0-20mA or 4-20mA. Of the two available speed inputs, one may be selected using SPEED1/SPEED2 allowing the user to preset two speeds that can be digitally selected. The MDrive34 will then accelerate/decelerate to the new value.

The MDrive34 Speed Control features step clock and direction output signals which may be used to control a second non-speed control MDrive to follow the speed of the Speed Control unit. This simplifies wiring and controlling machines with large tables or wide conveyors while eliminating drift between motor speeds.

There are two basic modes of operation: bidirectional and unidirectional. By moving the center point, both speed and direction are controlled by the analog speed control input. By setting the center point to zero or the lower end of the potentiometer, only velocity is controlled by the speed control input; direction is controlled by a separate digital input.

MDrive34 configurations include a single shaft rotary motor with optional internal optical encoder or a dual shaft version with control knob, a planetary gearbox, or a long life Acme screw linear actuator. The rotary MDrive34 is available in single, double and triple stack sizes: 24, 31 & 47. Interface connections are accomplished using 12.0" (30.5 cm) flying leads.

The MDrive34 Speed Control has 12 setup parameters, configured using the supplied IMS Analog Speed Control GUI. The setup parameters enable the user to configure all MDrive operational parameters which are stored in nonvolatile memory.

CONFIGURING

The IMS Analog Speed Control is a required software GUI for quick and easy parameter setup of the MDrive34 Speed Control from a computer parallel/SPI port. GUI access is via the IMS SPI Interface included on the CD shipped with the product, or download at www.imshome.com. An optional Parameter Setup Cable is available for ease of connecting and configuring the MDrive.

IMS Analog Speed Control features:

- Easy installation.
- Automatic detection of MDrive version and communication configuration.
- Will not set out-of-range values.
- Tool-tips display valid range setting for each option.
- Single screen interface.

MDRIVE34 SPEED CONTROL SPECIFICATIONS

GENERAL SPECIFICATIONS

Speed Control Input 1	0 to +5 VDC, 0 to 20 mA or 4 to 20 mA
Speed Control Input 2	0 to +5 VDC
A/D Resolution	10 bit
Speed Control Potentiometer Resistance.....	10 kΩ
Input Voltage (+V) Range*	+24 to +75 VDC
Step Clock, Direction Out (Drain Source Voltage Max).....	+100 VDC
Step Clock, Direction Out (Continuous Drain Current)	100 mA
Step Clock Output Pulse Width	3.64 μsec
Isolated Inputs.....	Speed1/Speed2/PWM, Start/Stop, Direction
Isolated Input Voltage Range (Sourcing or Sinking)	+5 to +24 VDC
PWM Input Frequency.....	15 to 25 kHz
Heat Sink Temperature (Max)	85° C
Motor Temperature (Max)	100° C
Protection	Over Voltage

*Power supply current requirements = 4A (maximum) per MDrive34. Actual power supply current will depend on voltage and load.

PARAMETERS

SETUP PARAMETERS				
NAME	FUNCTION	RANGE	UNITS	DEFAULT
ACCL	Accel/Decel	2000 to 65000	steps/sec ²	2000
C	Joystick Center	0 to 1022	counts	0
DB	Deadband	0 to 255	counts	1
DCLT	Decel Type	Decel at ACCL Rate/No Decel	--	Decel
IMODE	Source	Speed A1&A2, or PWM	--	A1&A2
	Analog Input	Volts/4-20mA/0-20mA	--	Volts
	Clockwise/Counter Clockwise	0 or 1	--	0
FS	Full Scale	1 to 1023	counts	1023
MHC	Motor Hold Current	0 to 100	percent	5
MRC	Motor Run Current	1 to 100	percent	25
MSEL	Microstep Resolution	2, 4, 5, 8, 10, 16, 25, 32, 50, 64, 125, 128, 250, 256	μsteps per step	256
RANGE	VI/VM Range	1 to 8	--	3
VI	Initial Velocity	1 to 100000	steps/sec	400
VM	Maximum Velocity	1 to 100000	steps/sec	20000

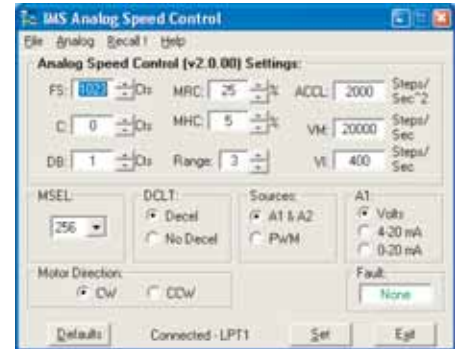

Configuring the MDrive Speed Control is simplified with the IMS Analog Speed Control's single screen interface, shown above. All parameters are set using the supplied IMS Analog Speed Control GUI. An optional Parameter Setup Cable is recommended with first orders.

WIRE/PIN ASSIGNMENTS

CONNECTOR P1 - Flying Leads	
WIRE COLOR	FUNCTION
Violet	STOP/START INPUT
Blue	DIRECTION INPUT
White/Brown	SPEED1/SPEED2/PWM INPUT
White	OPTOCOUPLER REFERENCE
White/Orange	STEP CLOCK OUTPUT
White/Blue	DIRECTION OUTPUT
Yellow	+5 VDC OUTPUT (10K POT)
Gray	LOGIC GROUND (10K POT)
Green	SPEED CONTROL INPUT 1: 0-5V (10K POT)/4-20mA/0-20mA
White/Green	SPEED CONTROL INPUT 2: 0-5V (10K POT)
Black	POWER GROUND
Red	+V (+24 TO +75 VDC)

CONNECTOR P2 (SPI) - 10 Pin Pin-Header	
PIN	FUNCTION
4	CHIP SELECT
5	GROUND
6	+5 VDC OUTPUT
7	MASTER OUT - SLAVE IN
8	CLOCK
10	MASTER IN - SLAVE OUT

ENCODER WIRE ASSIGNMENTS

ENCODER - Single-End	
WIRE COLOR	FUNCTION
Yellow/Black	GROUND
Yellow/Violet	INDEX
Yellow/Blue	CHANNEL A
Yellow/Red	+5 VDC INPUT
Yellow/Brown	CHANNEL B

ENCODER - Differential	
WIRE COLOR	FUNCTION
Yellow/Black	GROUND
Yellow/Violet	INDEX +
Yellow/Blue	CHANNEL A +
Yellow/Red	+5 VDC INPUT
Yellow/Brown	CHANNEL B +
Yellow/Gray	INDEX -
Yellow/Green	CHANNEL A -
Yellow/Orange	CHANNEL B -

NOTE: For recommended mating connector information, refer to the product's Quick Reference at www.imshome.com/quick.html

MDRIVE34 MOTOR SPECIFICATIONS

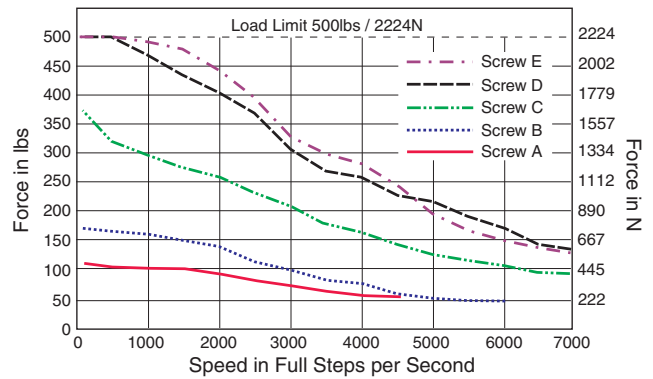
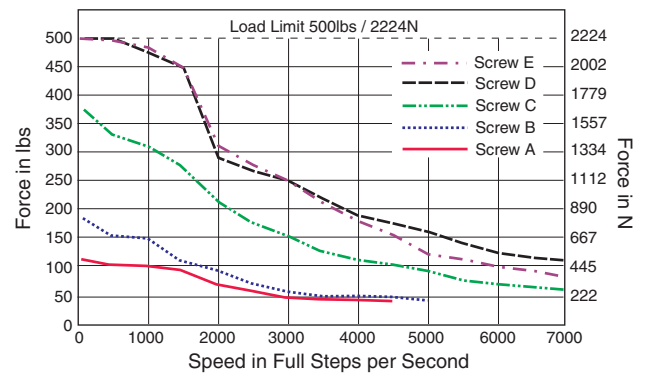
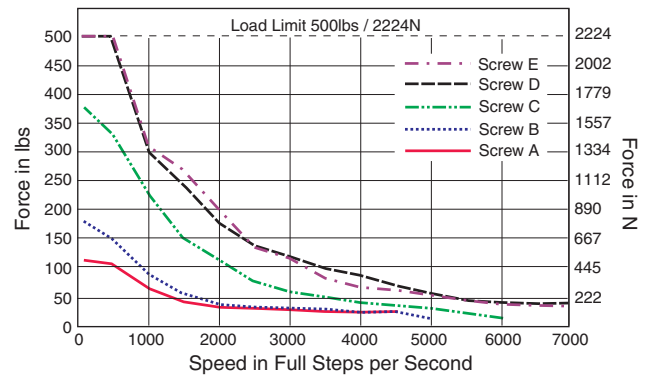

MDRIVE34 WITH PLANETARY GEARBOX

The MDrive34 is available with a Planetary Gearbox option developed to increase torque at lower speeds, enable better inertia matching and produce finer positional resolutions. These efficient, low maintenance Planetary Gearbox come fully assembled with the MDrive and are offered in a large number of

reduction ratios in 1-, 2- and 3-stage configurations. An optional NEMA Flange allows mounting the Planetary Gearbox to the load using a standard NEMA bolt circle. Planetary Gearbox may be combined with other MDrive34 options, however are unavailable on Linear Actuator versions.

Parameters

	1-Stage	2-Stage	3-Stage
Permitted Output Torque (oz-in/Nm)	2832/20.0	8496/60.0	16992/120.0
Gearbox Efficiency	0.80	0.75	0.70
Maximum Backlash (degree)	1.0°	1.5°	2.0°

Output Side With Ball Bearing

Maximum Load, Radial (lb-force/N)	90/400	135/600	225/1000
Maximum Load, Axial (lb-force/N)	18/80	27/120	45/200
Weight - Gearbox Only (oz/g)	64.4/1827	89.5/2538	114.6/3248
Weight - Gearbox & NEMA Flange (oz/g)	66.7/1890	92.6/2625	118.5/3360

PLANETARY GEARBOX MECHANICAL SPECIFICATIONS

Dimensions in Inches (mm)

Planetary Gearbox for MDrive34

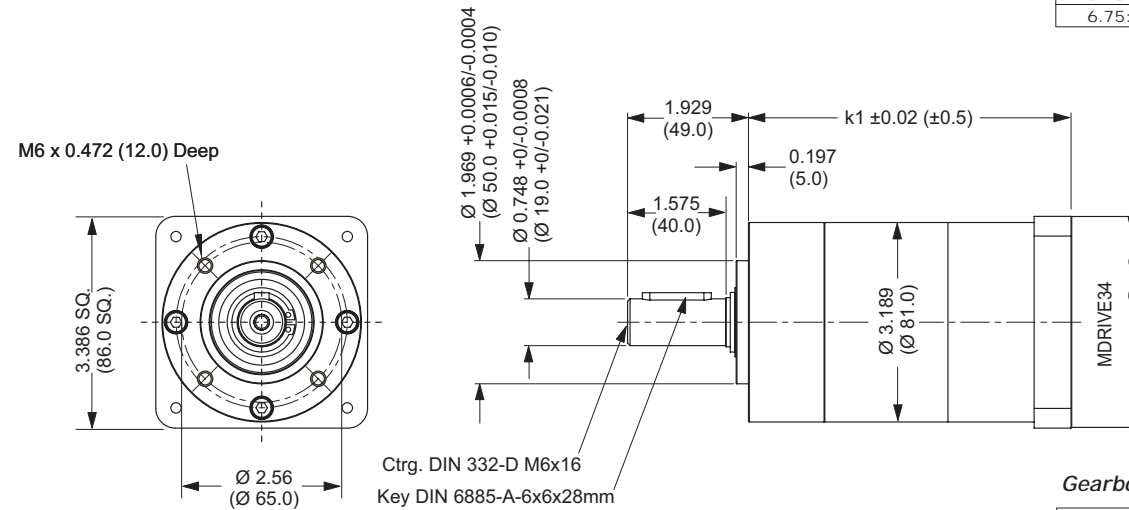

Gearbox Ratios (Rounded)

1-Stage	2-Stage	3-Stage
3.70:1	13.73:1	50.89:1
5.18:1	15.88:1	58.85:1
6.75:1	18.36:1	68.06:1
	19.20:1	71.16:1
	22.20:1	78.71:1
	25.01:1	92.70:1
	26.85:1	95.17:1
	28.93:1	99.50:1
	34.97:1	107.20:1
	45.56:1	115.07:1
		123.97:1
		129.62:1
		139.13:1
		149.90:1
		168.84:1
		181.24:1
		195.26:1
		236.09:1
		307.54:1

Planetary Gearbox with Optional NEMA Output Flange

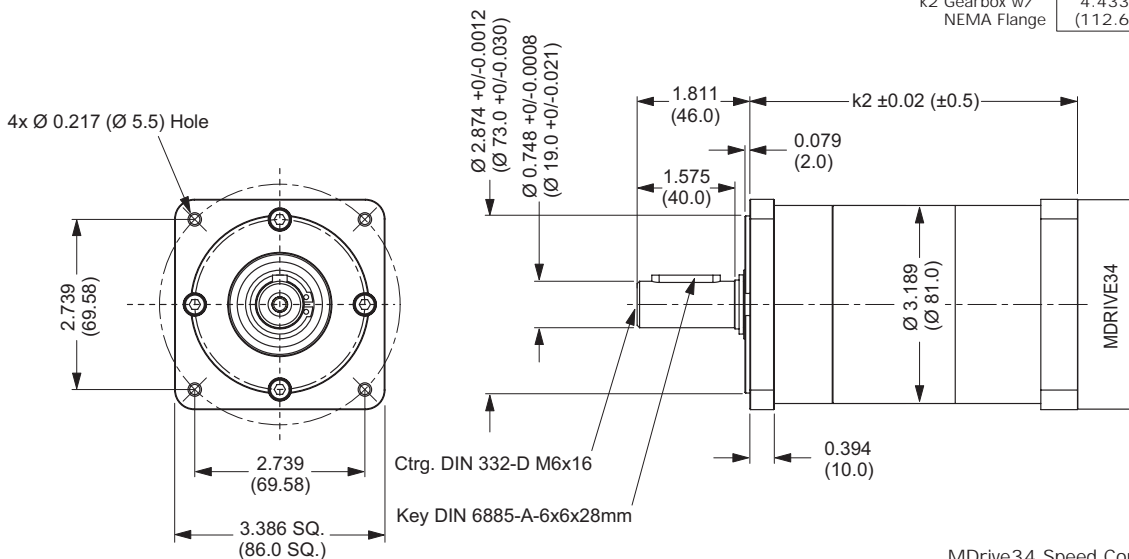

Gearbox Lengths Inches (mm)

	1-Stage	2-Stage	3-Stage
k1 Gearbox	4.315 (109.6)	5.169 (131.3)	6.024 (153.0)
k2 Gearbox w/ NEMA Flange	4.433 (112.6)	5.287 (134.3)	6.142 (156.0)

MDRIVE34 SPEED CONTROL - MECHANICAL SPECIFICATIONS

Dimensions in Inches (mm)

Rotary MDrive34: Single Shaft, Control Knob & Encoder Versions

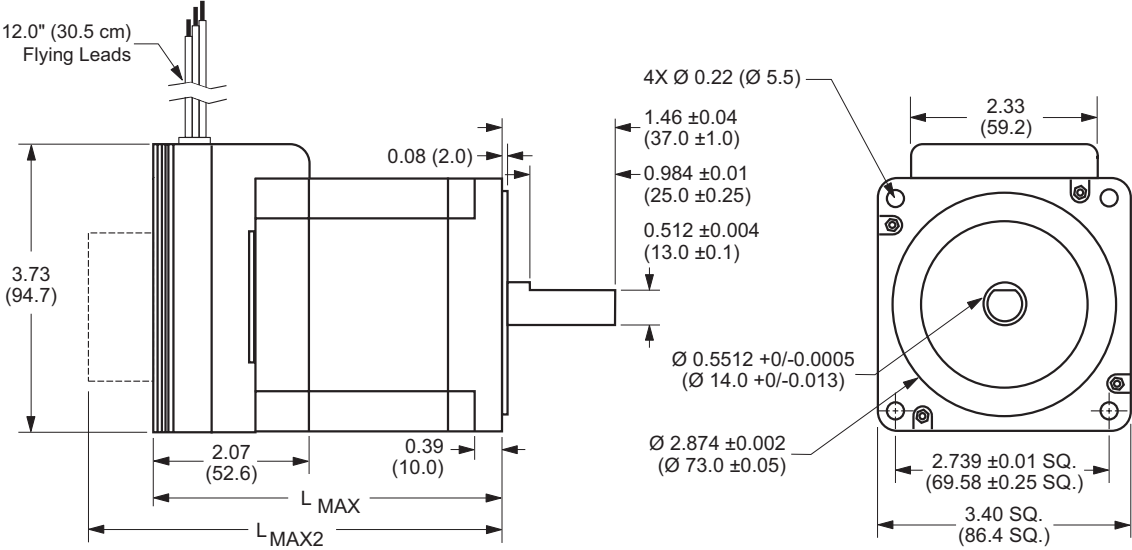

Linear Actuator MDrive34

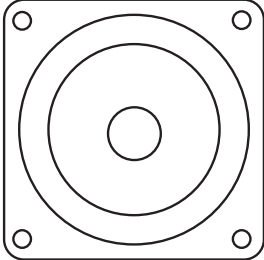

MDRIVE34 SPEED CONTROL - OPTIONS

Control Knob

The MDrive34 is available with a factory-mounted rear control knob for manual shaft positioning.

Planetary Gearbox

Efficient, low maintenance Planetary Gearbox are offered assembled with the MDrive34. Details inside.

Encoder

The MDrive34 is available with a factory-mounted internal optical encoder. Available line counts are 100, 200, 250, 400, 500 or 1000. All encoders, except the 1000 line, have an index mark. Encoders are available in both single-end and differential configurations.

Linear Actuator

The MDrive34 with long life Acme Screw Linear Actuator is available with the following travel/full step:

Screw A 0.005"/full step
 Screw B 0.0025"/full step
 Screw C 0.00125"/full step
 Screw D 0.000625"/full step
 Screw E 0.0005"/full step

Standard screw length is 6.0" (152.4mm) plus the mounting end thread. Custom lengths up to 24.0" are available without mounting end thread.

Linear Actuators are Non-Captive style. Contact the factory regarding Captive Shaft or External styles.

Parameter Setup Cable

A low cost accessory which eliminates the need for users to wire communications. This 6' (1.8m) cable includes built-in logic level shifting circuitry to accommodate the 3.3v ports on some PCs and plugs in easily to connect a standard DB-25 PC parallel/SPI port to the MDrive's 10 pin pin-header (P2). Order Cable Part No. MD-CC100-000.

ORDER INFORMATION

MDRIVE34 SPEED CONTROL	OPTIONS		
<p>Stack Sizes 24 = Single Stack 29 = Linear Actuator[†] 31 = Double Stack 47 = Triple Stack</p> <p>MDOF 34 <input type="checkbox"/> <input type="checkbox"/> <input type="checkbox"/> <input type="checkbox"/> <input type="checkbox"/> <input type="checkbox"/> <input type="checkbox"/> <input type="checkbox"/></p> <p>OPTION <input type="checkbox"/></p>	Control Knob	N	Example #2: MDOF3431N Adds a Control Knob to the part shown in example #1.
	Planetary Gearbox	G <input type="checkbox"/>	Example #3: MDOF3431G5 Rounding ratio to the nearest whole number, the above adds a Planetary Gearbox with 5.18:1 ratio to the part shown in example #1. Add -F if optional NEMA Flange is desired.
	Internal Encoder	E <input type="checkbox"/>	Example #4: MDOF3431ED500 Adds a 500 line count internal Differential Encoder to the part shown in example #1.
	Linear Actuator[†]	L <input type="checkbox"/>	Example #5: MDOF3429LA10.5 MDrive34 Speed Control Linear Actuator with a 0.005"/Full Step Acme Screw custom cut to 10.5". MAY NOT be combined with other options. Note: MDrive34 Linear Actuator Available <i>ONLY</i> in Stack Size 29
	<p>Screw Type (Travel/Full Step)</p> <p>A = 0.005" B = 0.0025" C = 0.00125" D = 0.000625" E = 0.0005"</p> <p>Custom Screw Length Range 2.0" to 24.0" Format XX.X eg. 08.5 for an 8.5" Screw (6.0" Screw Length Standard)</p>		<p>S = Single End D = Differential</p> <p>Line Count 100, 200, 250, 400, 500, 1000</p>
<p>Example #1: Part Number MDOF3431 is an MDrive34 Speed Control with Flying Leads, NEMA 34 motor, stack size 31.</p>			

[†]Stack Size 29 is only available as a Linear Actuator and is the **ONLY** size Linear Actuator offered. (MDOF3429LX)



P.O. Box 457, 370 N. Main Street
Marlborough, CT 06447 U.S.A.

Phone: 860/295-6102
 Fax: 860/295-6107
 E-mail: info@imshome.com
 Home Page: www.imshome.com

Distributed By:

TECHNICAL SUPPORT

Eastern U.S.
 Phone: 860/295-6102
 Fax: 860/295-6107
 E-mail: etech@imshome.com

Western U.S.
 Phone: 760/966-3162
 Fax: 760/966-3165
 E-mail: wtech@imshome.com

IMS MOTORS DIVISION

105 Copperwood Way, Suite H
 Oceanside, CA 92054
 Phone: 760/966-3162
 Fax: 760/966-3165
 E-mail: motors@imshome.com

IMS EUROPE GmbH

Hahnstrasse 10, VS-Schwenningen
 Germany D-78054
 Phone: +49/7720/94138-0
 Fax: +49/7720/94138-2
 E-mail: info@imseuropehome.com

European Sales Management

4 Quai Des Etroits
 69005 Lyon, France
 Phone: +33/4 7256 5113
 Fax: +33/4 7838 1537
 E-mail: bmartinez@imshome.com

German Sales/Technical Support

Phone: +49/35205/4587-8
 Fax: +49/35205/4587-9
 E-mail: hruhland@imshome.com

Product information covered by IMS Product Disclaimer available at www.imshome.com. Visit the IMS web site for the most up-to-date product information.

© 2002, 2004 Intelligent Motion Systems, Inc. All Rights Reserved.

REV122004